

**Project Location Map
EXHIBIT 1**

**Existing and Proposed
Roadway Typical Sections
EXHIBIT 2**

Typical Section - 116th Ave. to 57th Ave.

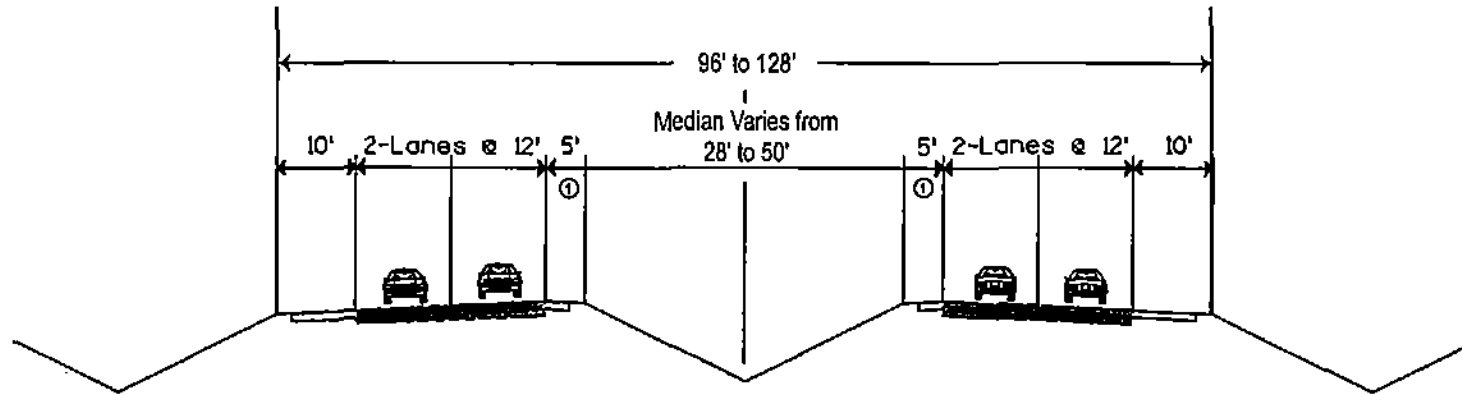

Existing Typical Section
(Total RW Varies from 160' to 235')

① East of 70th Avenue there are no inside shoulders.

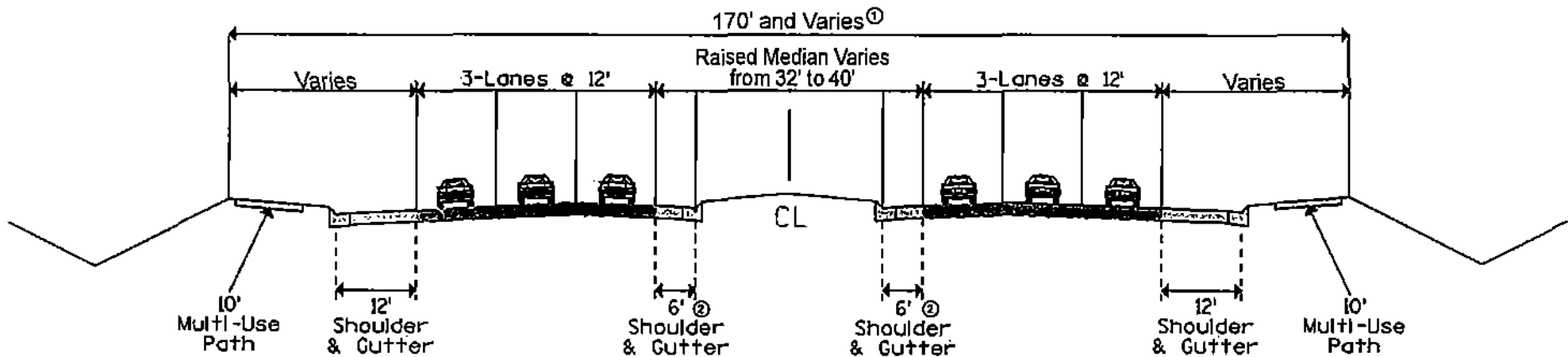

Proposed Typical Section

① The width of strip acquisitions varies based on impacts to abutting properties.

② East of 70th Avenue there are no proposed inside shoulders.

Typical Section - 57th Ave. to 52nd Ave.

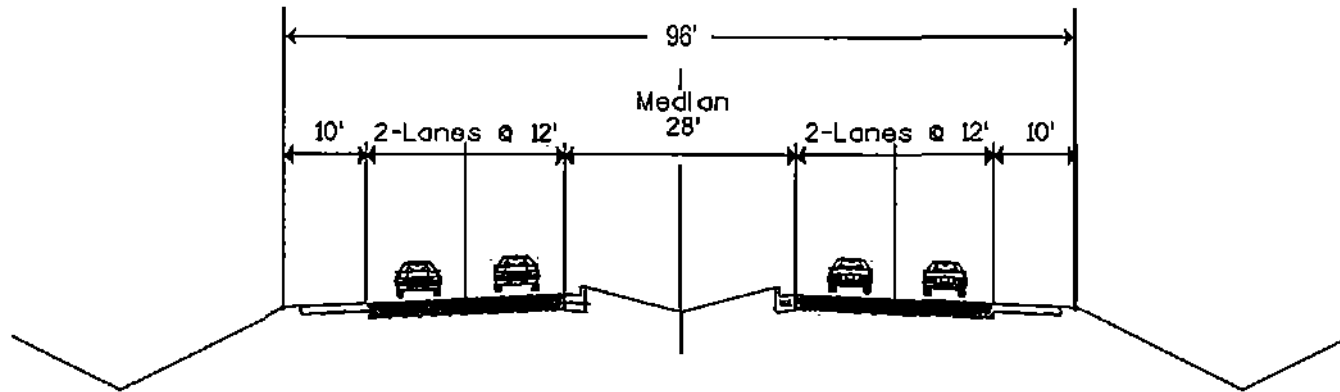

Existing Typical Section
(Total R/W Varies from 115' to 170')

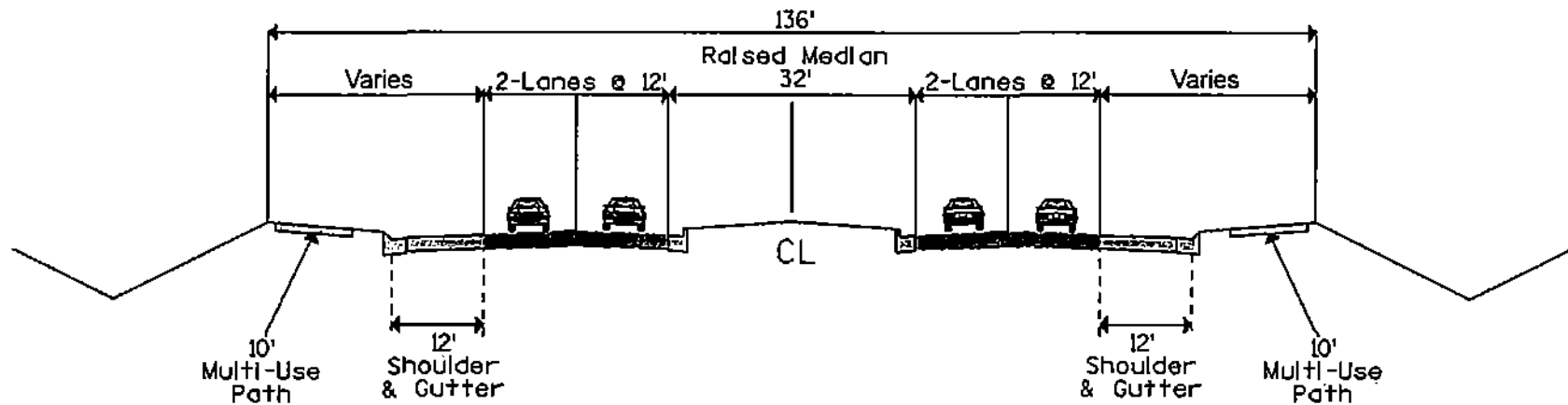

Proposed Typical Section

Typical Section - 52nd Ave. to 43rd Ave.

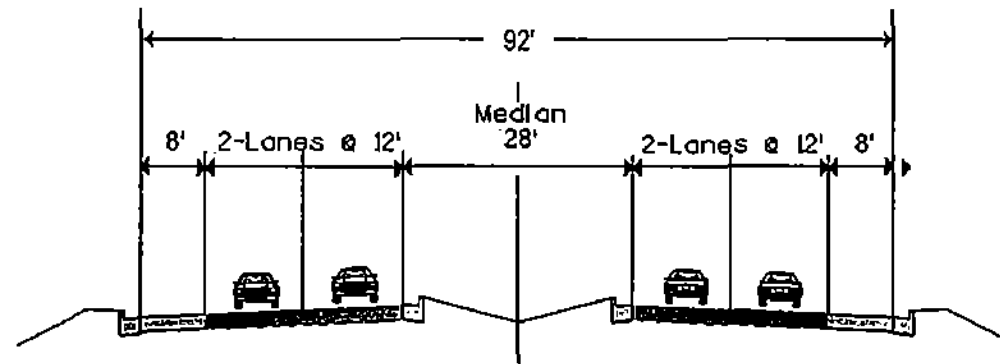

Existing Typical Section
(Total R/W Varies from 115' to 170')

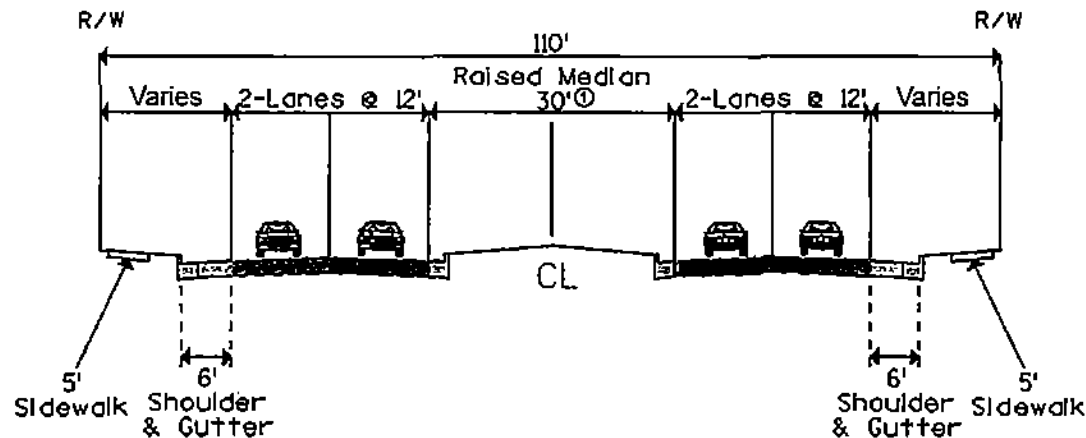

Proposed Typical Section

① East of 45th Street the roadway transitions to an undivided section.